

Original operating instructions

TOX®-FinePress
PFHL / PFHW

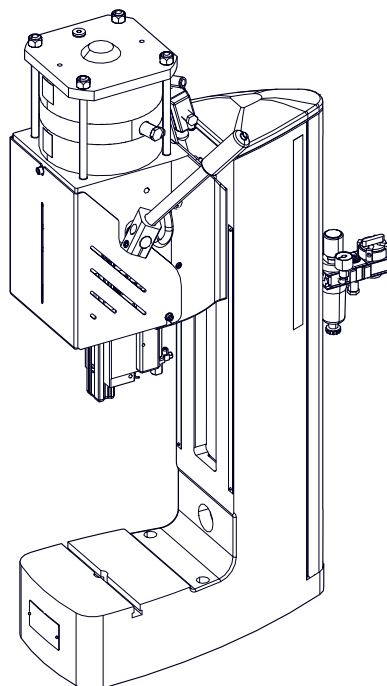

Table of contents

1	Important information	
1.1	Legal note	7
1.2	Exclusion of liability	7
1.3	Conformity	7
1.4	Validity of the document	8
1.4.1	Content and target group	8
1.4.2	Other applicable documents	8
1.5	Gender note	8
1.6	Displays in the document	9
1.6.1	Display of warnings	9
1.6.2	Display of general notes	10
1.6.3	Highlighting of texts and images	10
1.7	Contact and source of supply	11
2	Safety	
2.1	Basic safety requirements	13
2.2	Organizational measures	14
2.2.1	Safety requirements for the operating company	14
2.2.2	Selection and qualifications of personnel	15
2.3	Fundamental hazard potential	16
2.3.1	Electrical hazards	16
2.3.2	Thermal hazards	16
2.3.3	Pneumatic hazards	17
2.3.4	Contusions	17
2.3.5	Hydraulic hazards	17
2.3.6	Electromagnetic hazards	18
2.3.7	Laser	18
2.3.8	Hazardous substances	18
2.3.9	Noise	19
2.4	Safety symbols	20

3	About this product	
3.1	Intended use	21
3.1.1	Safe and correct operation	21
3.1.2	Foreseeable misuse	22
3.1.3	Substances harmful to the wetting properties of lacquers (LABS)	22
3.2	Product identification	22
3.2.1	Type plate	22
3.3	Product overview and function description	23
4	Technical data	
4.1	Type sheet and data sheet	25
4.2	Compressed air press force table	25
5	Transport and storage	
5.1	Safety during transport	27
5.2	Storage when not in use	28
5.3	Transport by lifting device	29
5.4	Dispatch for repair	30
6	Installation	
6.1	Safety during installation	31
6.2	Requirements for installation	33
6.2.1	Set-up location	33
6.3	Installing accessories	34
6.3.1	Installing process monitoring (option)	34
6.3.2	Installing the stroke counter (optional)	35
6.3.3	Installing the force sensor (optional)	36
6.3.4	Installing travel sensor (option)	38
6.3.5	Installing the slide table (optional)	40
6.3.6	Installing the tool holding fixture (optional)	41
6.3.7	Install the TDC sensor (option)	42
6.3.8	Install the BDC sensor (option)	44

7	Commissioning	
7.1	Safety during the commissioning	47
7.1.1	Safety device.....	47
7.2	Requirements for the commissioning.....	48
8	Operation	
8.1	Safety in operation	49
8.2	Requirements for operation.....	49
8.3	Process monitoring	50
8.4	Setting the open height of the press head	51
8.5	Fine adjustment of working stroke	54
8.6	Resetting the stroke counter (optional)	55
9	Troubleshooting	
9.1	Safety during troubleshooting	57
9.2	Detecting faults	58
	Maintenance table	
10	Maintenance	
10.1	Safety during maintenance	61
10.2	Requirements for maintenance	63
10.2.1	Set system to maintenance position	63
10.3	TOX®-FinePress maintaining	64
10.3.1	TOX®-FinePress inspecting	64
10.3.2	Inspecting the fastening of the press head	65
10.3.3	Inspecting and cleaning movable parts and guides	66
11	Repairs	
11.1	Safety and repairs	67

12 Disassembly and Disposal

12.1	Safety during disassembly and disposal	69
12.2	Decommissioning	70
12.3	Shutdown	70
12.4	Disassembling	71
12.5	Disposal	71

13 Appendices

13.1	Declaration of conformity	73
------	---------------------------------	----

Index

1 Important information

1.1 Legal note

All rights reserved.

Operating instructions, manuals, technical descriptions and software published by TOX® PRESSOTECHNIK GmbH & Co. KG ("TOX® PRESSOTECHNIK") are copyright and must not be reproduced, distributed and/or otherwise processed or edited (e.g. by copying, microfilming, translation, transmission in any electronic medium or machine-readable form). Any use - including of extracts - contrary to this condition is prohibited without approval in writing by TOX® PRESSOTECHNIK and may be subject to criminal and civil legal sanctions.

If this manual refers to goods and/or services of third parties, this is for example only or is a recommendation by TOX® PRESSOTECHNIK.

TOX® PRESSOTECHNIK does not accept any liability or warranty/guarantee with reference to the selection, specifications and/or usability of these goods and services. The use and/or representation of trademarked brands that do not belong to TOX® PRESSOTECHNIK are for information only; all rights remain the property of the owner of the trademarked brand.

Operating instructions, manuals, technical descriptions and software are originally compiled in German.

1.2 Exclusion of liability

TOX® PRESSOTECHNIK has checked the contents of this publication to ensure that it conforms to the technical properties and specifications of the products or plant and the description of the software. However, discrepancies may still be present, so we cannot guarantee complete accuracy. The supplier documentation included with the system documentation is an exception.

However, the information in this publication is checked regularly and any required corrections are included in subsequent editions. We are grateful for any corrections and suggestions for improvement. TOX® PRESSOTECHNIK reserves the right to revise the technical specifications of the products or plant and/or the software or documentation without prior notice.

1.3 Conformity

The product is compliant with EU guidelines.

See separate EU-declaration of conformity or installation declaration.

1.4 Validity of the document

1.4.1 Content and target group

This manual contains information and instructions for the safe operation and safe maintenance or servicing of the product.

- All information in this manual is up to date at the time of print. TOX® PRESSOTECHNIK reserves the right to make technical changes that improve the system or increase the standard of safety.
- The information is intended for the operating company as well as operating and service personnel.

1.4.2 Other applicable documents

In addition to the available manual, further documents can be supplied. These documents must also be complied with. Other applicable documents can be, for example:

- additional operating manuals (e.g. of components or of a whole system)
- Supplier documentation
- Instructions, such as software manual, etc.
- Technical data sheets
- Safety data sheets
- Data sheets
- Schematics

1.5 Gender note

In order to enhance readability, references to persons that also relate to all sexes are normally only stated in the usual form in German or in the corresponding translated language in this manual, thus e.g. "operator" (singular) for male or female, or "operators" (plural) for male or female". This should in no way convey any gender discrimination or any violation of the principle of equality, however.

1.6 Displays in the document

1.6.1 Display of warnings

Warning signs indicate potential dangers and describe protective measures. Warning signs precede the instructions for which they are applicable.

Warning signs concerning personal injuries

DANGER

Identifies an immediate danger!

Death or severe injuries will occur if appropriate safety measures are not taken.

→ Measures for remedial action and protection.

WARNING

Identifies a potentially dangerous situation!

Death or serious injury may occur if appropriate safety measures are not taken.

→ Measures for remedial action and protection.

CAUTION

Identifies a potentially dangerous situation!

Injury may occur if appropriate safety measures are not taken.

→ Measures for remedial action and protection.

Warning signs indicating potential damage

NOTE

Identifies a potentially dangerous situation!

Property damage may occur if appropriate safety measures are not taken.

→ Measures for remedial action and protection.

1.6.2 Display of general notes

General notes show information on the product or the described action steps.



Identifies important information and tips for users.

1.6.3 Highlighting of texts and images

The highlighting of texts facilitates orientation in the document.

✓ Identifies prerequisites that must be followed.

1. Action step 1

2. Action step 2: identifies an action step in an operating sequence that must be followed to ensure trouble-free operation.

▷ Identifies the result of an action.

▶ Identifies the result of a complete action.

➔ Identifies a single action step or several action steps that are not in an operating sequence.

The highlighting of operating elements and software objects in texts facilitates distinction and orientation.

- <In square brackets> identifies operating elements, such as buttons, levers and (valves) stopcocks.
- "with quotation marks" identifies software display panels, such as windows, messages, display panels and values.
- **In bold** identifies software buttons, such as buttons, sliders, check-boxes and menus.
- **In bold** identifies input fields for entering text and/or numerical values.

1.7 Contact and source of supply

Only use original spare parts or spare parts approved by TOX® PRESSOTECHNIK.

TOX® PRESSOTECHNIK GmbH & Co. KG

Riedstraße 4

88250 Weingarten / Germany

Tel. +49 (0) 751/5007-333

E-Mail: info@tox-de.com

For additional information and forms see
www.tox-pressotechnik.com

2 Safety

2.1 Basic safety requirements

The product is state of the art. However, operation of the product may involve danger to life and limb for the user or third parties or damage to the plant and other property.

For this reason the following basic safety requirements will apply:

- Read the operating manual and observe all safety requirements and warnings.
- Operate the product only as specified and only if it is in perfect technical condition.
- Remedy any faults in the product or the plant immediately.

2.2 Organizational measures

2.2.1 Safety requirements for the operating company

The operating company is responsible for compliance with the following safety requirements:

- The operating manual must always be kept available at the operation site of the product. Ensure that the information is always complete and in legible form.
- In addition to the operating manual, the generally valid legal and other binding rules and regulations must be provided for the following content and all personnel must be trained accordingly:
 - Work safety
 - Accident prevention
 - Working with hazardous substances
 - First aid
 - Environmental protection
 - Traffic safety
 - Hygiene
- The requirements and contents of the operating manual must be supplemented by existing national regulations (e.g. for prevention of accidents and for environmental protection).
- Instructions for special operating features (e.g. work organization, work processes, appointed personnel) and supervisory and reporting obligations must be added to the operating manual.
- Take action to ensure safe operation and make sure that the product is maintained in a functional condition.
- Only allow authorized persons access to the product.
- Ensure that all personnel work with awareness of safety and potential dangers with reference to the information in the operating manual.
- Provide personal protective equipment.
- Maintain all safety and information on dangers regarding the product complete and in legible condition and replace as required.
- Do not make any changes, carry out attachments or conversions to the product without the written approval of TOX® PRESSOTECHNIK. Action contrary to the above will not be covered by the warranty or the operating approval.
- Make sure that the annual safety inspections are carried out and documented by an expert.

2.2.2 Selection and qualifications of personnel

The following safety requirements are applicable for the selection and qualifications of personnel:

- Only appoint persons to work on the plant who have read and understood the operating manual, and in particular, the safety instructions before starting work. This is particularly important for persons who only work on the plant occasionally, e.g. for maintenance work.
- Only allow persons appointed and authorized for this work access to the plant.
- Only appoint reliable and trained or instructed personnel.
- Only appoint persons to work in the danger zone of the plant who can perceive and understand visual and acoustic indications of danger (e.g. visual and acoustic signals).
- Ensure that assembly and installation work and the initial commissioning are performed exclusively by qualified personnel who have been trained and authorized by TOX® PRESSOTECHNIK.
- Maintenance and repairs must be performed by qualified and trained personnel only.
- Ensure that personnel who are being trained, instructed or are in an apprenticeship can only work on the plant under the supervision of an experienced person.
- Have work on electrical equipment performed only by electricians or trained persons under the direction and supervision of an electrician in accordance with the electrotechnical regulations.

2.3 Fundamental hazard potential

Fundamental hazard potentials exist. The specified examples draw attention to known hazardous situations, but are not complete and do not in any way provide safety and risk awareness action in all situations.

2.3.1 Electrical hazards

Attention should be paid to electrical hazards particularly inside the components in the area of all assemblies of the control system and motors of the installation.

The following basically applies:

- Have work on electrical equipment performed only by electricians or trained persons under the direction and supervision of an electrician in accordance with the electrotechnical regulations.
- Always keep the control box and/or terminal box closed.
- Before commencing work on electrical equipment, switch off the main switch of the system and secure it against being switched back on inadvertently.
- Pay attention to the dissipation of residual energy from the control system of the servomotors.
- Make sure that the components are disconnected from the power supply when carrying out the work.

2.3.2 Thermal hazards

The drive works in continuous operation and can become hot and cause burns when touched.

- Wear individual protective equipment.
- Before starting work, make sure that surfaces have cooled down sufficiently.

2.3.3 Pneumatic hazards

Attention must be paid to pneumatic hazards particularly on the pneumatic supply lines and connection points.

The following basically applies:

- Allow work to be carried out on pneumatic equipment by authorized service personnel only.
- Wear individual protective equipment.
- Do not exceed the permissible pressure.
- First switch on compressed air when all hose connections have been established and secured.
- Do not uncouple any hoses under pressure.
- If hoses slip off, switch off the compressed air supply immediately.

2.3.4 Contusions

Contusions and hand injuries can occur in the radius of action of the product.

The following applies generally:

- Make sure that that no persons are located in the danger area during operation.
- During necessary work in the danger area (e.g. maintenance, cleaning), secure the system against unexpected, accidental and unauthorized activation.
- Make sure that parts or tools cannot fall down or descend as a result of stored energy. Use appropriate fuses.

2.3.5 Hydraulic hazards

Attention must be paid to hydraulic hazards particularly on the supply lines, connection points and vent points.

The following applies generally:

- Allow work to be carried out on hydraulic equipment by authorized service personnel only.
- Wear individual protective equipment.
- Do not exceed the permissible pressure.
- Do not remove any hoses under pressure.
- Never vent hydraulic components under pressure.

2.3.6 Electromagnetic hazards

Electromagnetic hazards are to be taken into account in the area of electromagnetically vibrating or oscillating components.

Regular work on and with electromagnetically vibrating or oscillating components can cause disorders in the blood flow of the fingers as well as neurological and motoric dysfunctions.

The following applies generally:

- Wear protective anti-vibration gloves when performing necessary work!
- Electromagnetic fields can have an indirect effect on heart pacemakers and other implants. Adhere to safety distances.

2.3.7 Laser

Depending on the model and features, lasers can be installed for the purpose of recognition. There is a danger of looking into the laser in some situations. If this is not avoided, eye injuries may result.

The following applies generally:

- Do not look into the direct or the reflected beam.
- If the laser beam hits the eye, deliberately close the eyes and move the head immediately out of the beam.
- When using the laser, no optical instruments are to be used for viewing the source of the beam, since this can lead to exceeding the exposure limit values.
- Manipulation (modification) of the laser equipment is inadmissible.

2.3.8 Hazardous substances

The following safety requirements apply when handling chemical substances:

- Observe the applicable safety regulations on handling chemical substances and the information on the manufacturer's safety data sheets of hazardous substances.
- Wear individual protective equipment.
- In the event of eye or skin contact, rinse the affected area, change contaminated clothing and visit a doctor if necessary. Provide appropriate equipment (eye wash bottle, washbasin) near the workplace.
- Groundwater hazardous substances must not get into the ground or sewage system. Collect groundwater hazardous substances and dispose of them properly.

2.3.9 Noise





Depending on the equipment, an increase in the noise level can arise in the sphere of the product.

- Keep the duration of the exposure at a minimum.
- Wear individual protective equipment.

2.4 Safety symbols

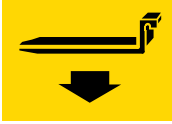
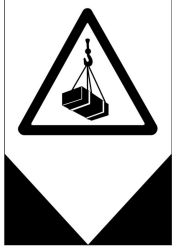
Safety symbols are important components of the safety concept and help to prevent accidents. The safety symbols provide information about potential hazards that could cause serious injuries.

The following safety symbols can be attached on the product:

Symbol	Hazard	Notes
	Warning of suspended load	Do not stay in the danger zone of the suspended load.
		Identifies fork-lift truck brackets.
		Identifies attachment point.
	Warning of hot surfaces	In the area of motors, drives and fans.
	Warning of electrical voltage	In the area of the entire control box.
	Warning of crushing	Risk of crushing in the working area.

Tab. 1 Safety symbols

3 About this product

3.1 Intended use

The press in conjunction with the designated tool is used for

- Installing, pressing
- Punching, pressing (of function elements)
- Riveting, crimping, flaring
- Punching, piercing
- Embossing, marking
- Tensioning, clamping, crimping
- Pressing, compressing
- Clinching, joining

of sheet metal or mechanical modules.

3.1.1 Safe and correct operation

Intended use includes the following conduct:

- Only operate with the components for which it is specified.
- Follow all instructions in this operating manual.
- Comply with the specified maintenance intervals and perform maintenance work correctly.
- Operate in compliance with the conditions of the technical data.
- Operation with fully assembled and functional safety devices.
- Activities may only be carried out by persons who are qualified or authorized for this purpose.

Any other use or application beyond this does not come under the scope of intended use.

3.1.2 Foreseeable misuse

Use contrary to intended use includes the following foreseeable misuse:

- Operation under conditions that deviate from the technical data.
- Operation without fully assembled and functional connections.
- Operation without fully assembled and functional safety devices.
- Modifications to the product without prior approval by TOX® PRES-SOTECHNIK and the approving authority.
- Incorrect parameterization.
- Execution of activities by persons who are not qualified or authorized to do so.

The operating company is exclusively responsible for all personal injury and property damage resulting from non-intended use. Non-intended use will not be covered by the warranty or the operating approval.

3.1.3 Substances harmful to the wetting properties of lacquers (LABS)

No substances containing silicone, are knowingly processed and used.

3.2 Product identification

3.2.1 Type plate

The details on the type plate ensure clear identification of components and the specific operating parameters.

The type plate is attached permanently on the component.

3.3 Product overview and function description

For the TOX®-FinePress the ram is moved forward over a toggle mechanism by pulling on the hand lever. In this position a limit switch is actuated which triggers a pneumatic power stroke of 6 mm after the the start button is pressed. The return stroke is initiated when the start button is released.

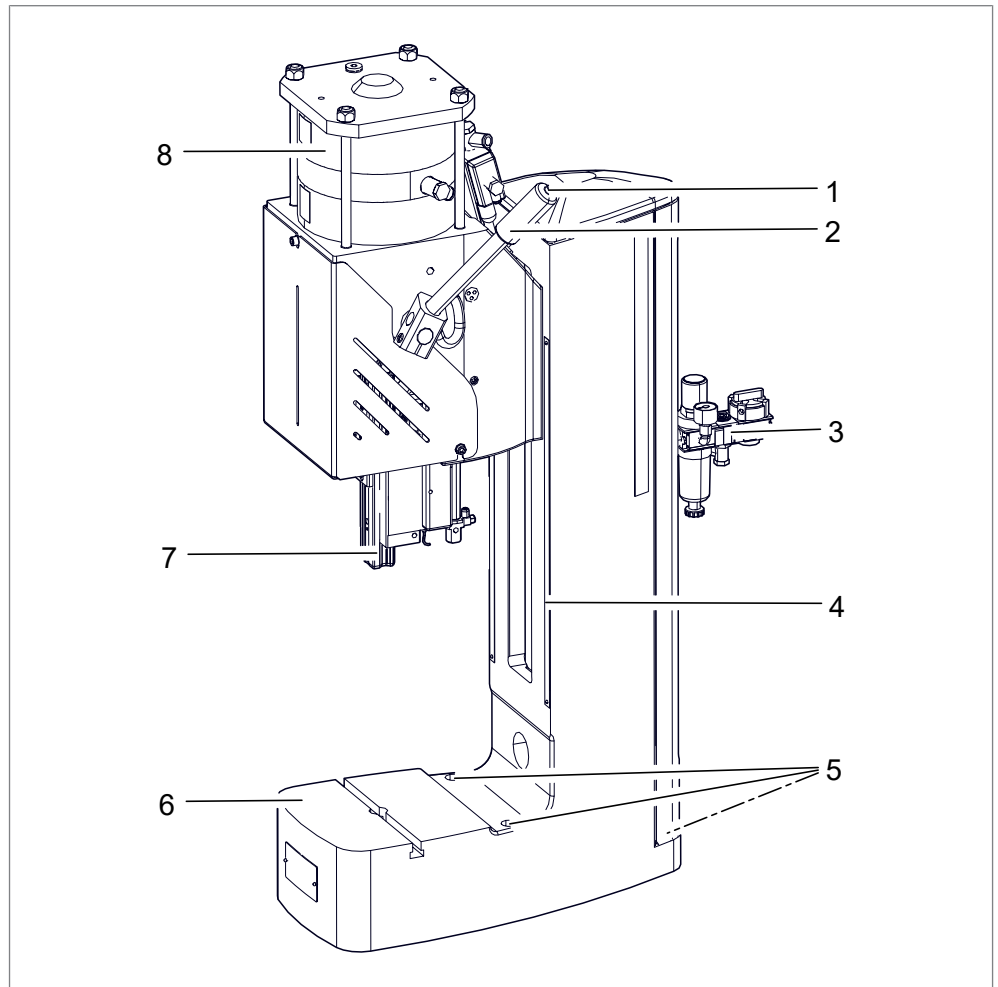

Fig. 1 Product overview

	Designation	Function
1	Start button	Triggers the power stroke.
2	Hand lever	Drives the ram onto the workpiece.
3	Compressed air supply	Supplies the TOX®-FinePress with compressed air.
4	Height adjustment scale	Facilitates the adjustment of the open height.
5	Fastening holes	For screw fitting to the floor.
6	Press bed	With T-groove for taking up tools.
7	Ram	Transfers the force to the workpiece.
8	Drive	Performs the power stroke for processing the workpiece.

4 Technical data

4.1 Type sheet and data sheet

For technical data and installation dimensions see data sheet.
www.tox-pressotechnik.com

4.2 Compressed air press force table

Air pressure [bar]	PFHx 008 Force F [kN]	PFHx 013 Force F [kN]	PFHx 022 Force F [kN]	PFHx 033 Force F [kN]	PFHx 056 Force F [kN]
2	2.9	4.4	7.5	11.4	19.0
2.5	3.6	5.4	9.1	14.2	23.5
3	4.4	6.6	11.0	17.1	28.4
3.5	5.2	7.7	13.1	19.9	33.1
4	5.9	8.8	15.2	23.0	38.0
4.5	6.7	10.0	17.1	25.7	42.9
5	7.4	11.1	19.2	28.8	47.6
5.5	8.2	12.2	21.2	31.6	52.4
6	8.9	13.4	23.0	34.4	57.4

Tolerance of the technical specifications $\pm 5\%$.

5 Transport and storage

5.1 Safety during transport

WARNING

Hazard from suspended loads!

Severe crushing, impacts and serious accidents as a result of improper transportation and falling load!

- Only use lifting gear that is appropriate and in perfect technical condition, as well as load attachment devices with an adequate safe working load.
- Never stand or work under suspended loads.
- Make sure that that no person is in the danger area.
- When transporting and setting down, make sure that no parts of the body become jammed.
- Wear suitable personal protective equipment (e.g. safety boots).

CAUTION

Injury from toppling and falling products!

- Secure product from toppling, falling, accidentally moving.
- Store product horizontally or secure with dowels.

- The transportation may only be carried out by authorized personnel.
- The product may only be transported with empty liquid containers.
- The product may only be transported with the transport pallet or transport device provided.
- The product may only be lifted with suitable lifting devices at suitable lifting points.
See [Chap. 2.4 Safety symbols, Page 20](#).
- Note the weight of the product.
See technical data sheet.
- Note the center of gravity of the product.
See general arrangement drawing.

5.2 Storage when not in use

⚠ CAUTION

Injury from toppling and falling products!

- Secure product from toppling, falling, accidentally moving.
- Store product horizontally or secure with dowels.

The following applies:

- Do not store the product outdoors.
- Protect the product against the influence of the weather.
- Avoid temperature fluctuations, so as to prevent corrosion from condensation.
- Seal connection openings.

5.3 Transport by lifting device

A threaded bore hole is provided for a ring bolt for lifting the TOX®-Fine-Press.

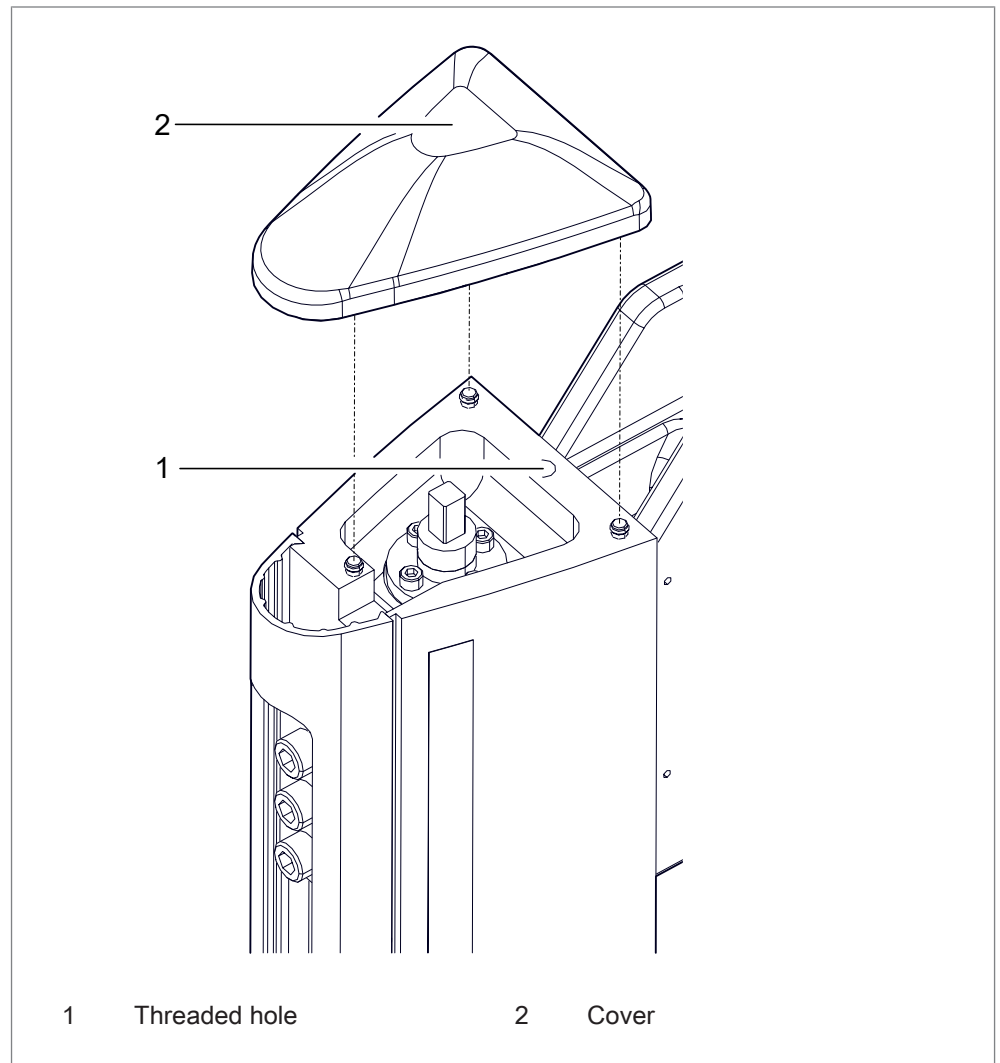

1. Remove the cover from the press frame.
2. Remove the crank, ring bolt and other loose parts from the TOX®-Fine-Press.
3. Screw the ring bolt into the threaded bore.

5.4 Dispatch for repair

To dispatch the product for repair to TOX® PRESSOTECHNIK, please proceed as follows:

- Fill in the "Accompanying repair form". This we supply in the service sector on our website or upon request via e-mail.
- Send us the completed form via e-mail.
- Then you will receive the shipping documents from us via e-mail.
- Send us the product with the shipping documents and a copy of the "Accompanying repair form".

For contact data see: [Chap. 1.7 Contact and source of supply, Page 11](#) or www.tox-pressotechnik.com.

6 Installation

6.1 Safety during installation

The installation may only be carried out by trained and authorized service personnel.

DANGER

Electrical hazards in case of contact with live parts!

Electric shock, burns or death in case of contact with live parts!

- Have all work on the electrical equipment performed by an electrician.
- Disconnect power supply.
- Wait for residual energy to dissipate safely (at least 3 minutes).

WARNING

Ejecting parts and compressed air from compressed air conducting lines!

Serious injuries to eyes and body cavities!

- Always connect and disconnect lines without pressure.
- Pay attention to maximum permitted pressures.
- Wear individual protective equipment.

WARNING

Danger due to fast lever movement!

Serious impacts and contusions!

- Push the hand lever to the top before connecting the compressed air supply.

⚠ WARNING**Hazard from suspended loads!**

Severe crushing, impacts and serious accidents as a result of improper transportation and falling load!

- Only use lifting gear that is appropriate and in perfect technical condition, as well as load attachment devices with an adequate safe working load.
- Never stand or work under suspended loads.
- Make sure that that no person is in the danger area.
- When transporting and setting down, make sure that no parts of the body become jammed.
- Wear suitable personal protective equipment (e.g. safety boots).

6.2 Requirements for installation

6.2.1 Set-up location

The set-up location:

- Must be free from dust and dirt
- Must be a closed room
- Must have a firm, level floor
- Must have sufficient space and easy access to the system parts
- Prevent the spray of sparks
- The floor must have sufficient load bearing capacity for the weight of the system parts and stresses caused by movements
- The stability must be ensured



Information on technical data, operating conditions, etc. for the intended use can be found in type sheet or the product-specific data sheet and circuit diagram.



The plant must be screwed to the substrate.

6.3 Installing accessories

6.3.1 Installing process monitoring (option)

- Please see the separate operating manual for the installation of the process monitoring system.

6.3.2 Installing the stroke counter (optional)

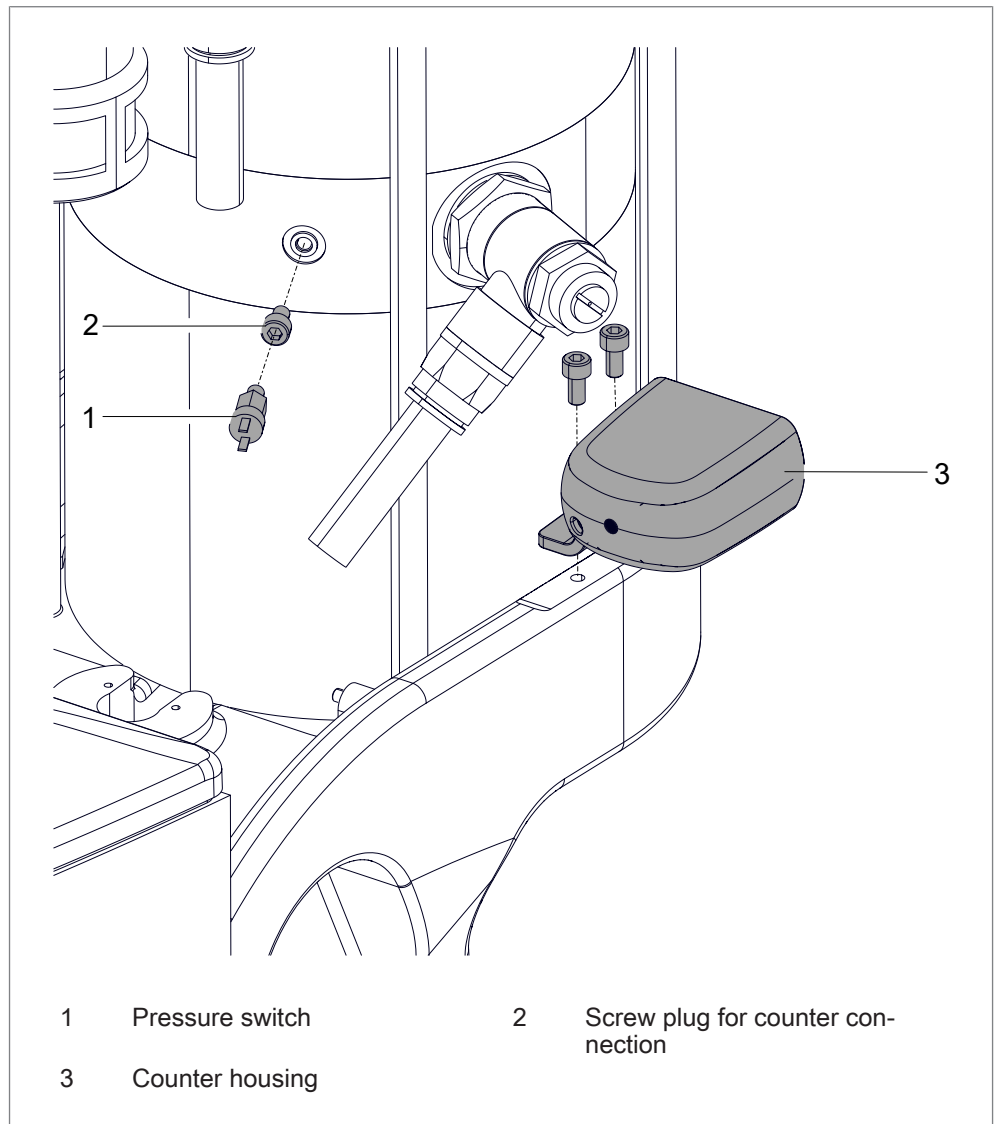

1. Disconnect the cable set from the counter housing.
2. Screw out the screw plug on the counter connection.
3. Install the pressure switch in the counter connection.
4. Install the counter housing on the press head.
5. Connect the cable set with the counter housing and pressure switch.

6.3.3 Installing the force sensor (optional)

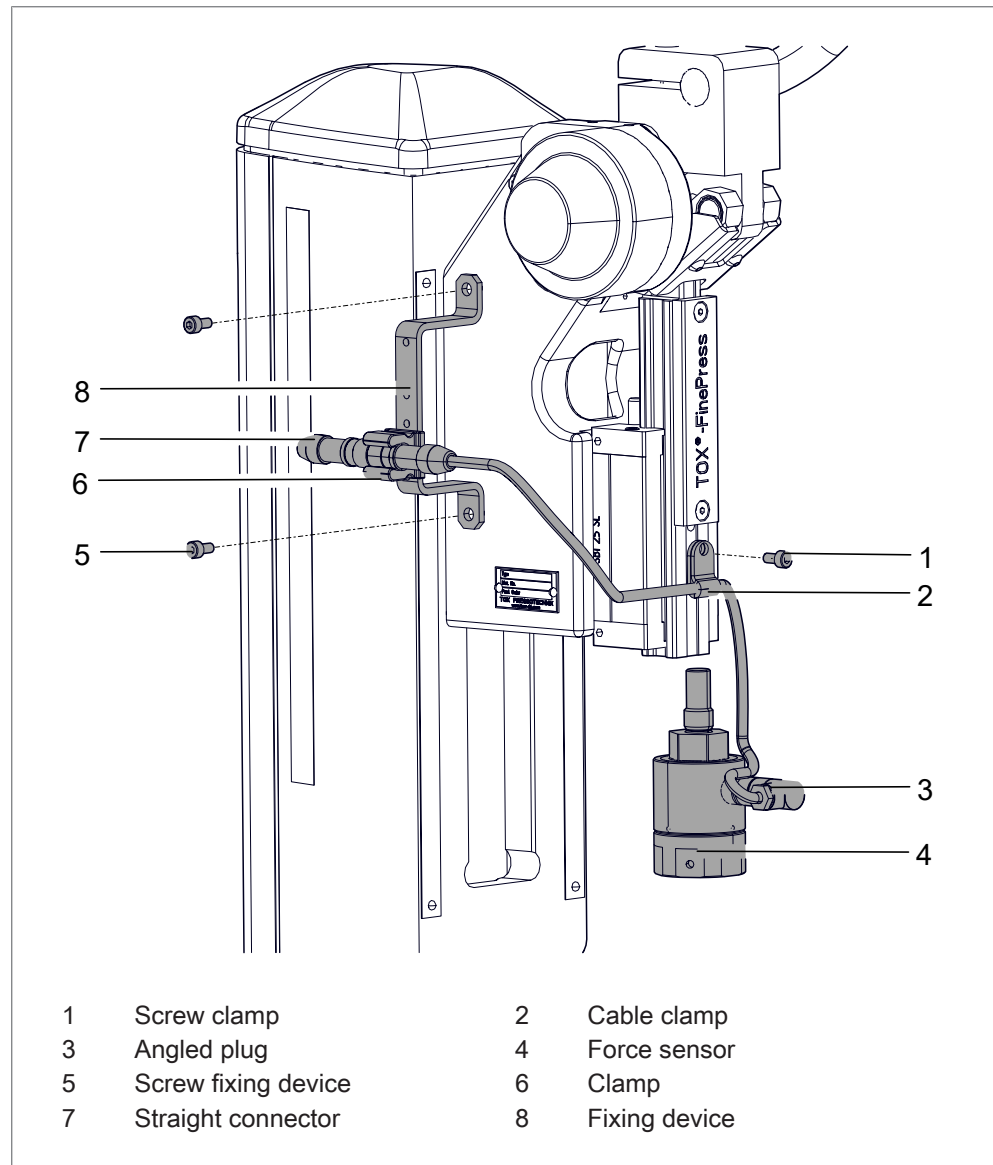

1. Screw the fixing device onto the press head.
2. Screw the force sensor onto the ram.
3. Fasten the cable clamp with the screw.
4. Connect the angled plug to the force sensor.
5. Screw the clamp in the lowest position onto the fixing device.
6. Connect the straight connector to the evaluation unit and insert it into the clamp.

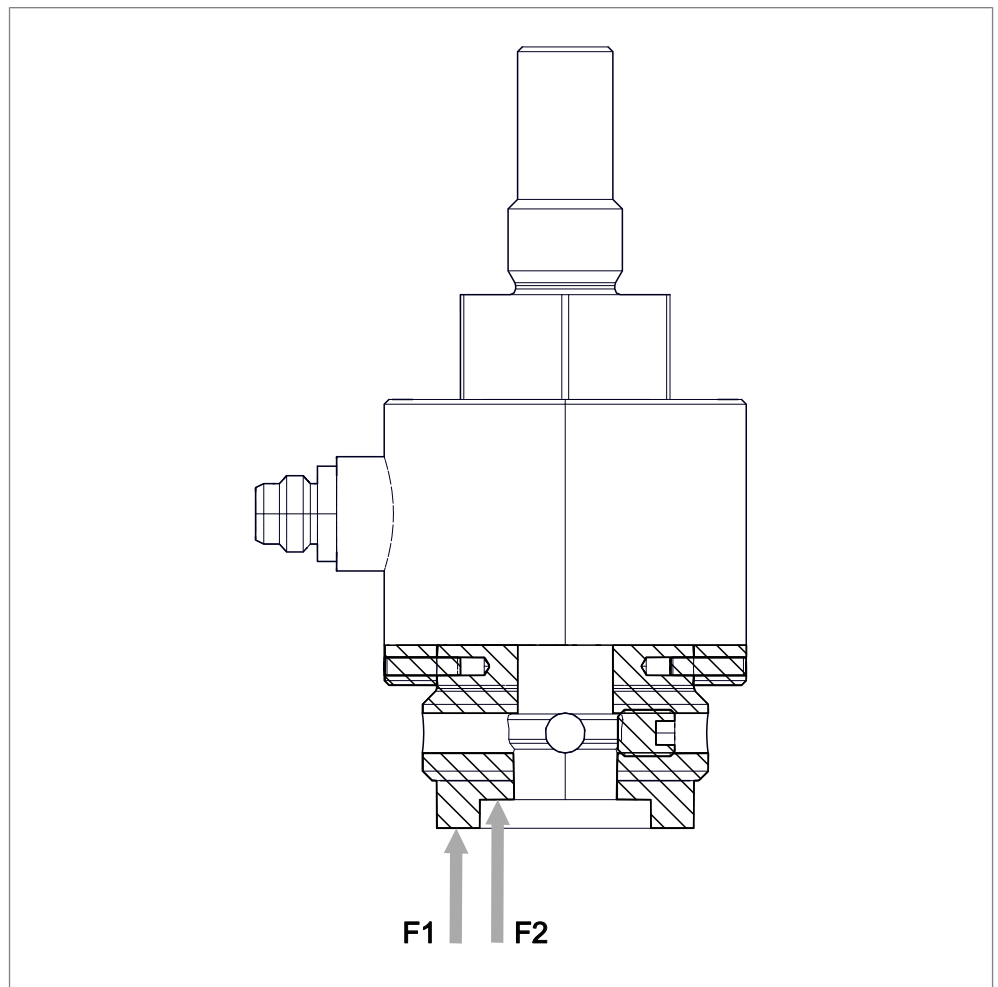

→ **NOTE!** Observe the maximum thread length!
The tool must bear against flange 1 or flange 2.

6.3.4 Installing travel sensor (option)

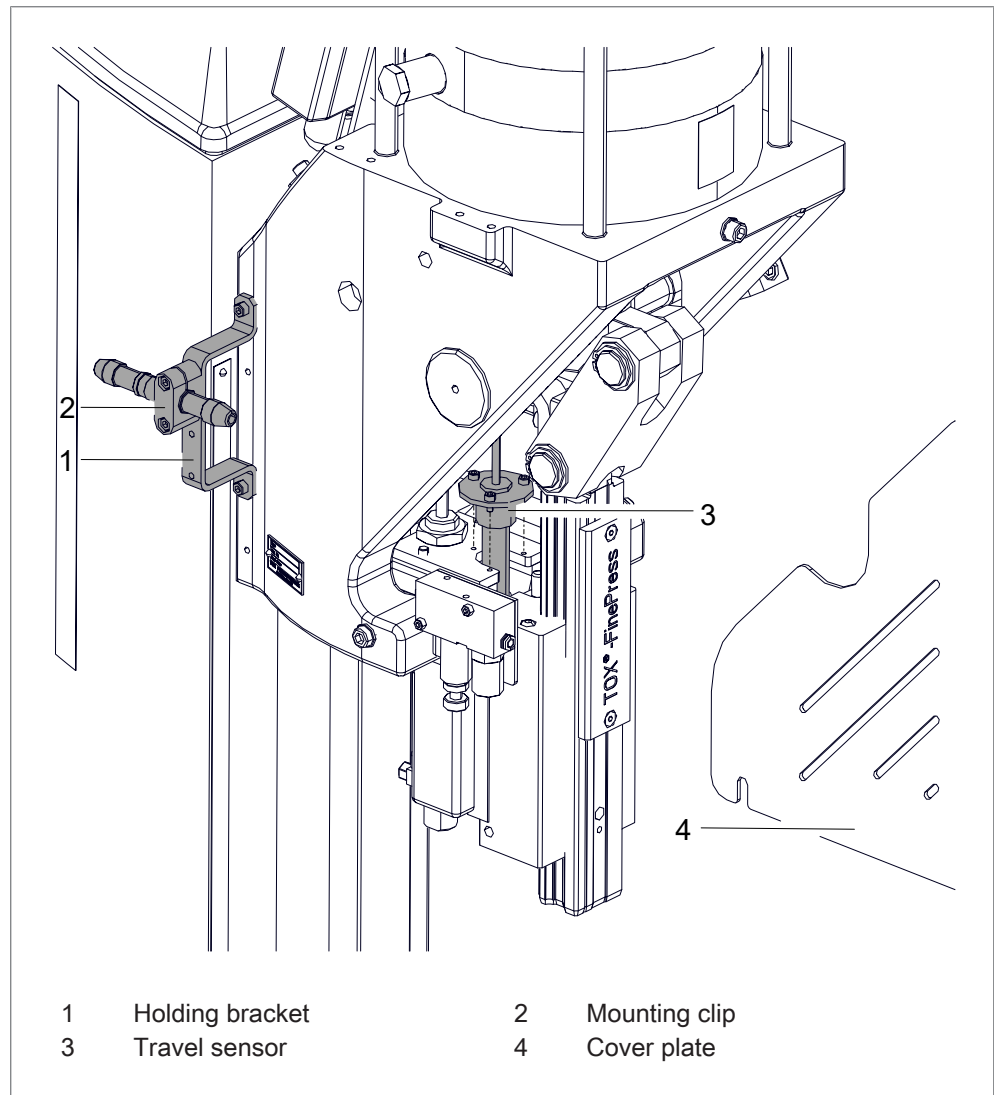

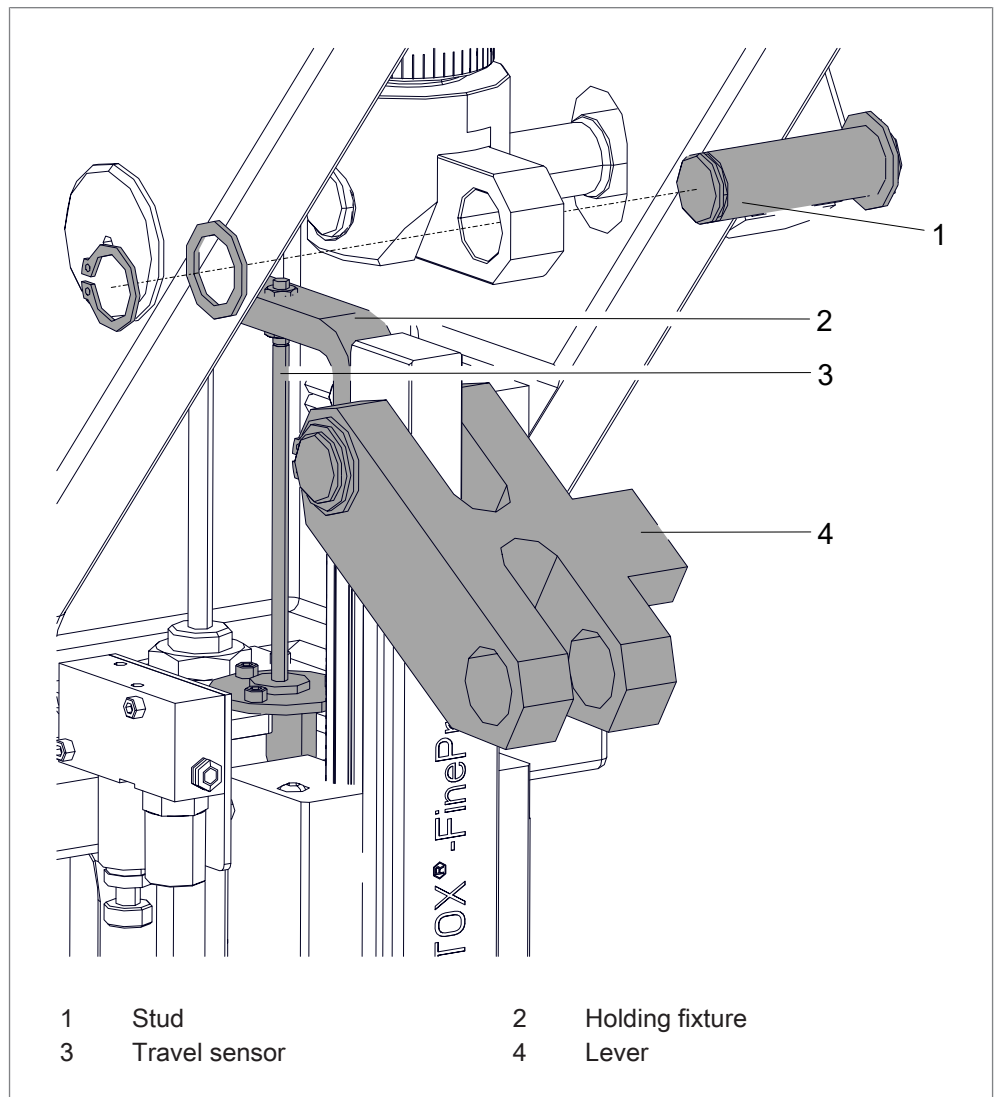

1. Dismantle the cover plate.
2. For easier access the lever can be folded down.
3. Install the holding bracket on the press head.
4. Install the travel sensor on the press head.
5. Install the travel sensor on the holding fixture.
6. Connect the cable to the evaluation unit.
7. Install the straight plug in the mounting clip.
8. Install the cover plate.

6.3.5 Installing the slide table (optional)

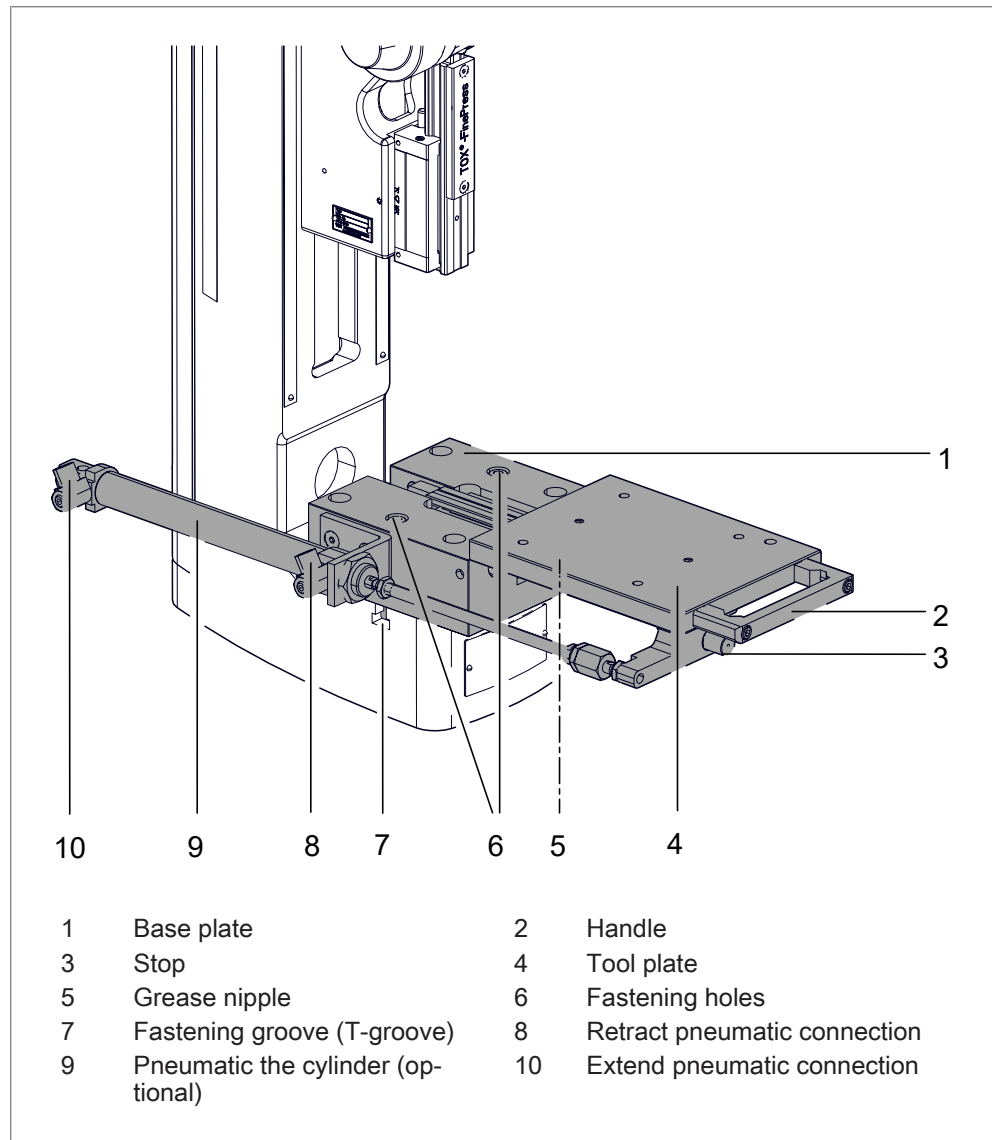

1. Insert the T-groove nuts into the fastening groove of the press frame.
2. Pull out the tool plate until the fastening holes are accessible.
3. Screw the base plate over the mounting holes using the T-groove nuts.
4. The insertion width is set via the stop.

6.3.6 Installing the tool holding fixture (optional)

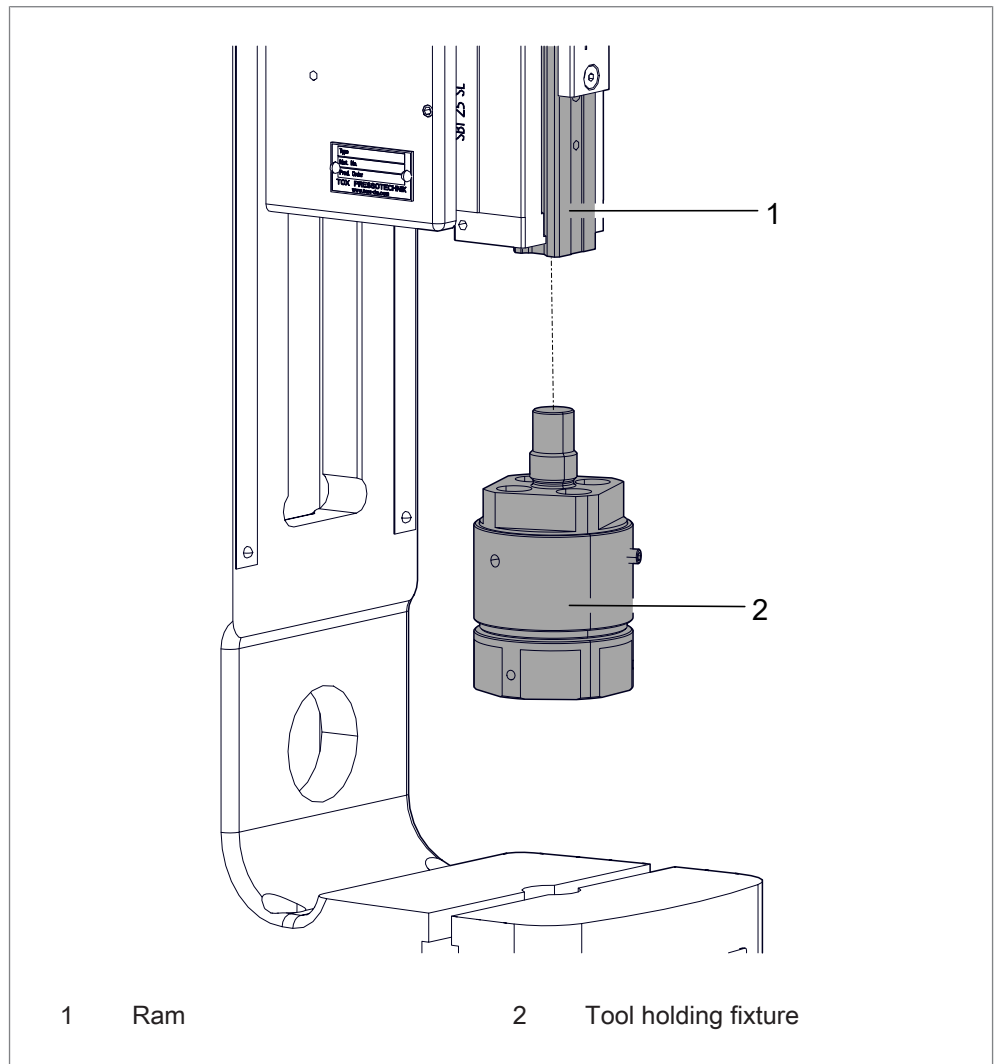

➔ The tool holding fixture is screwed into the ram.

For technical data and installation dimensions see data sheet.

www.tox-pressotechnik.com



6.3.7 Install the TDC sensor (option)

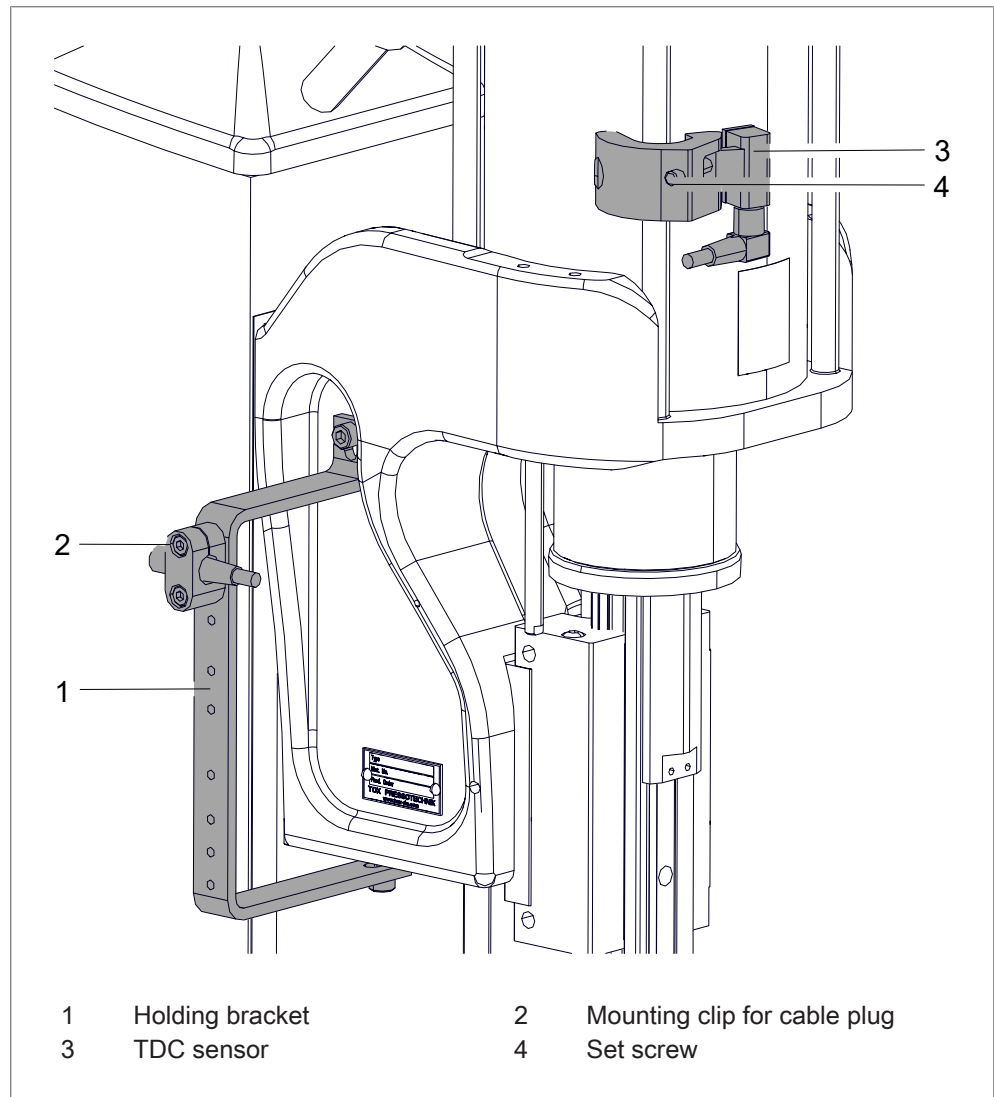

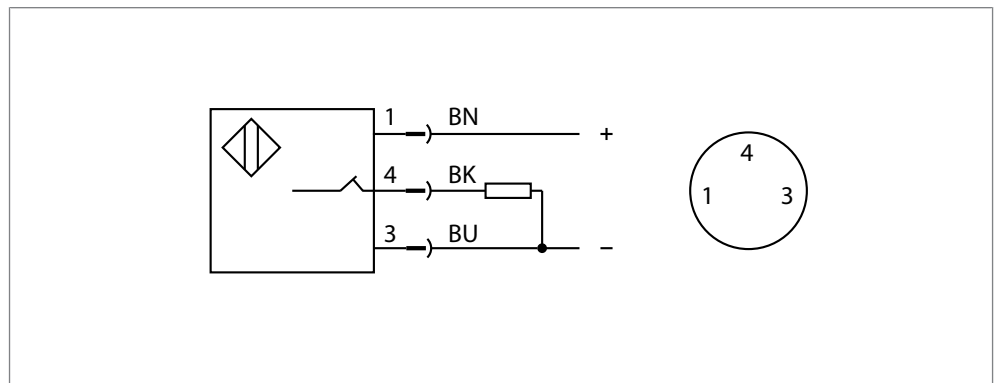
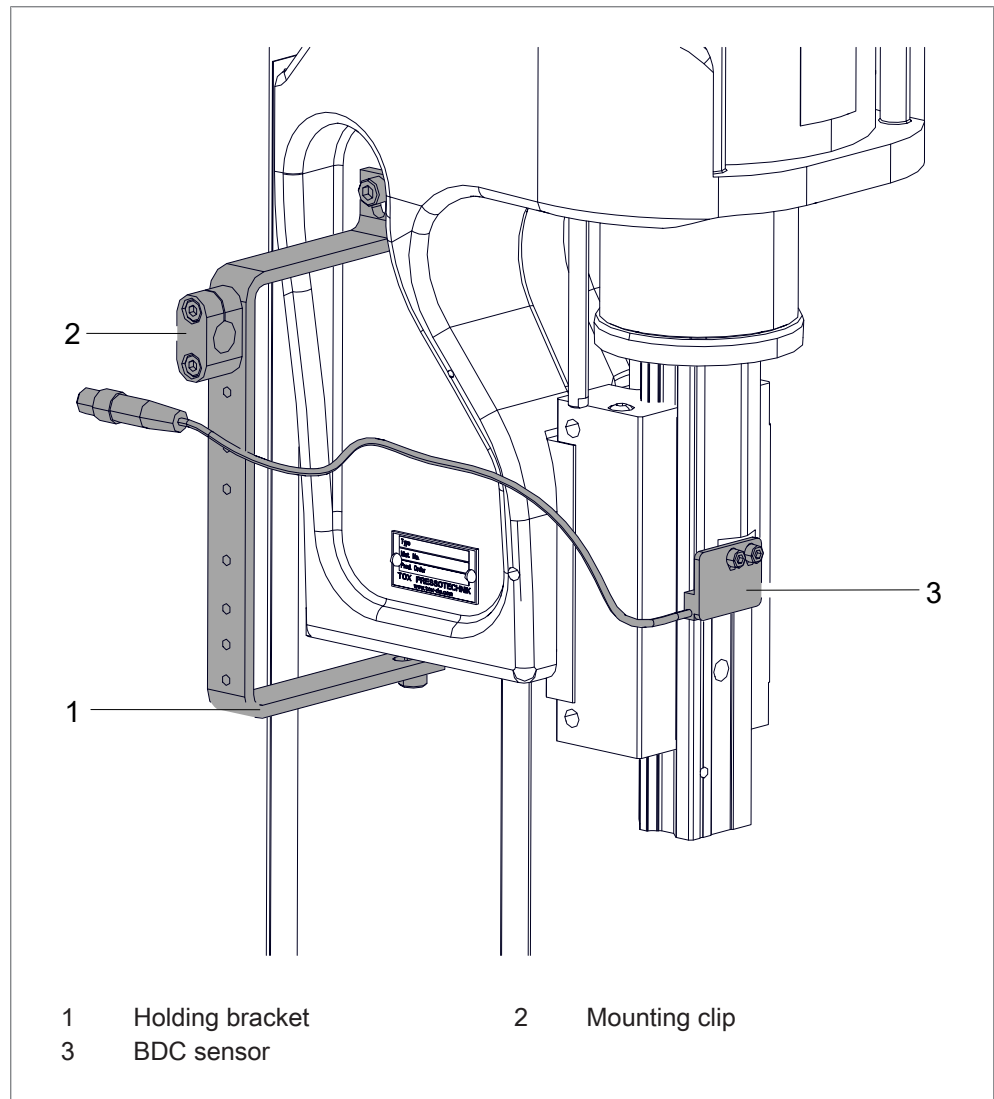

Fig. 2 Allocation of TDC sensor: (BMF 21K-PS-C-2-S49)

1. Install the holding bracket on the press head.
2. Position the TDC sensor with holding angle on the tension rod by shifting until a signal is appears on the measuring instrument.
3. Install the TDC sensor with holding angle on the tension rod.
4. Set the distance from the TDC sensor via the set screw. The TDC sensor must bear against the pneumatic cylinder.
5. Connect the cable and install the straight plug in the mounting clip.

6.3.8 Install the BDC sensor (option)



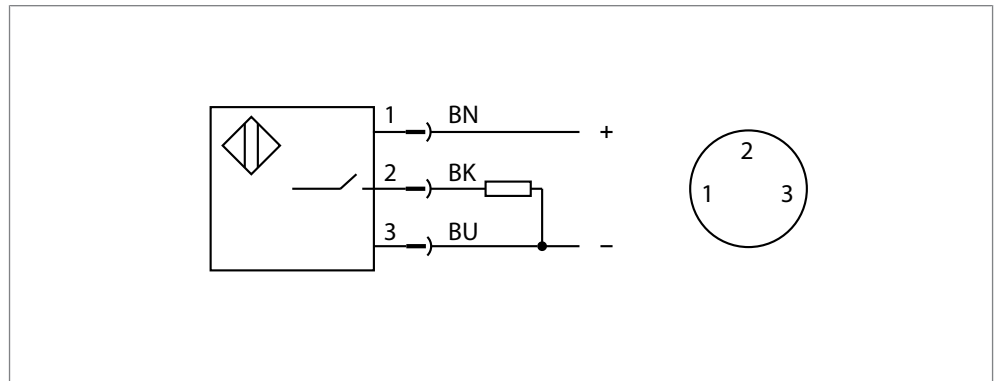

Fig. 3 Allocation of the BDC sensor: (BES R04KC-POC15B-S49-00,13)

1. Install the holding bracket on the press head.
2. Install the BDC sensor on the ram.
3. Connect the cable to the evaluation unit.
4. Install the cable plug in the mounting clip.

7 Commissioning

7.1 Safety during the commissioning

The system may only be commissioned by trained and authorized service personnel.

7.1.1 Safety device

All safety equipment must be properly assembled and functional.

7.2 Requirements for the commissioning

The requirements are:

- All components are properly installed.
- The safety devices of the entire system are properly assembled and functional.
- Any transport locks are removed.
- Supply connections, communication and control connections, material or media hoses are installed properly. The permissible values are complied with.
- The necessary software for controlling the component is installed.
- TOX® PRESSOTECHNIK has released the system and associated components for commissioning.
- No tools, installation equipment or other interfering objects may be left in the tool area or working area.

8 Operation

8.1 Safety in operation

WARNING

Dangerous machine movements!

Serious contusions and injuries!

- Make sure that that no persons are located in the danger area during operation.

CAUTION

Noise during operation!

Hearing impairment!

- Wear individual protective equipment.

CAUTION

Hazard from flying parts!

Injuries to eyes and body cavities!

- Wear individual protective equipment.

CAUTION

Dangerous lever movements!

Contusions and impacts!

- Always hold the hand lever.
- Release it only when it is in the top initial position.

8.2 Requirements for operation

- The safety devices of the entire system are properly assembled and functional.
- All piece parts are intact and properly maintained.
- Supply connections, communication and control connections, material or media hoses are installed properly. The permissible values are complied with.

8.3 Process monitoring

See the separate operating manual for the installation of the process monitoring system.

8.4 Setting the open height of the press head

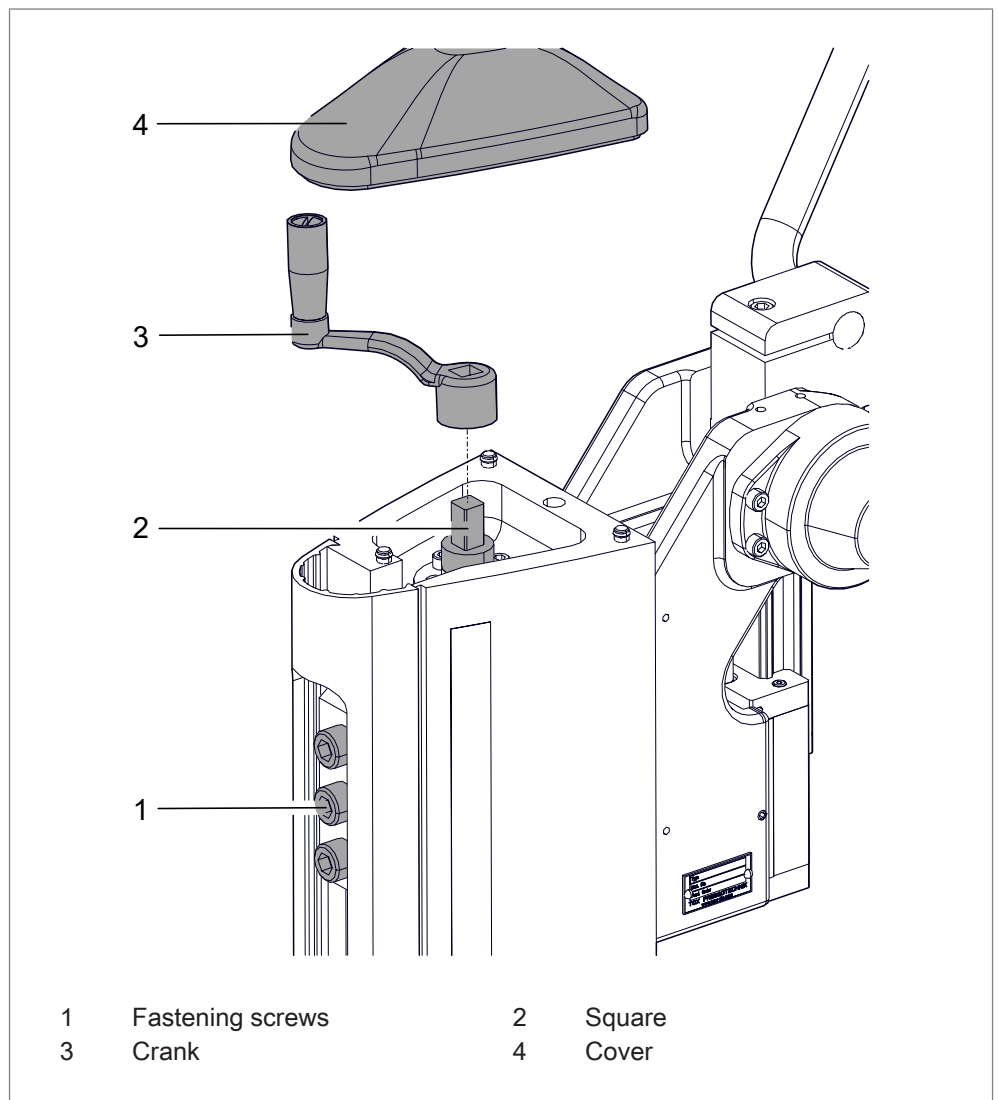

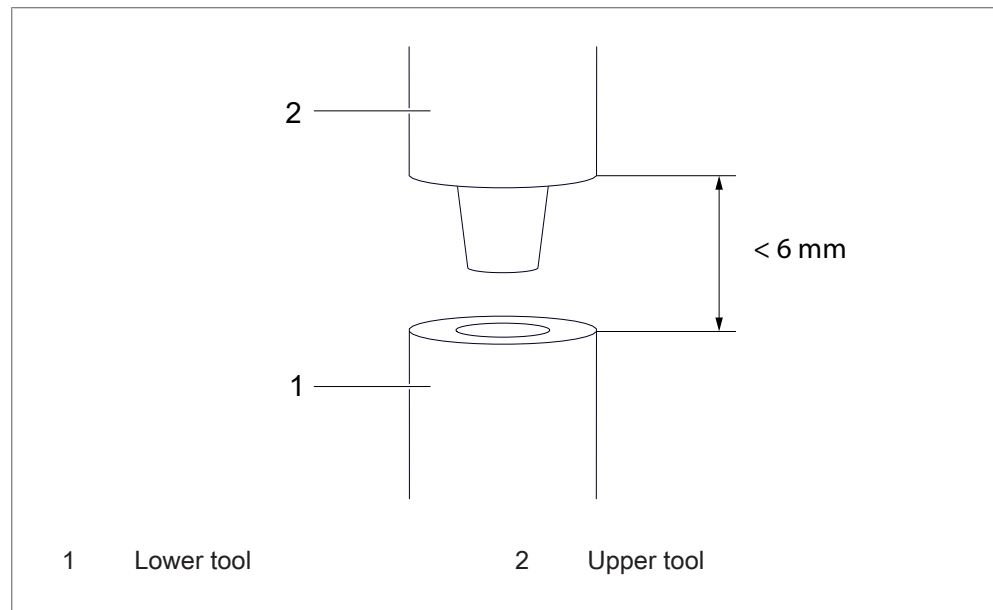

Fig. 4 Example: Tool opening pinch-off edge <math>< 6 \text{ mm}</math>

⚠ WARNING

Dangerous machine movements!

Serious contusions and injuries!

- Use only safe tools.
- When triggering the limit switch the gap between the moving tool parts must not exceed a maximum of 6 mm.
- If necessary, install additional safety devices, e.g. fixed casings.

NOTE! Damage on the press! Do not exert force on the ram during the in-feed movement!

NOTE! Damage on the tool or the workpiece! Calculate the open height before starting operation!

- ✓ Set the fine adjustment on the largest opening. See [Chap. 8.5 Fine adjustment of working stroke, Page 54](#).
- 1. Remove the cover from the press frame.
- 2. Loosen the fastening screws of the clamping plate. Do not unscrew the screws!
- 3. Place the supplied crank onto the square and adjust the open height by turning it.
Turning clockwise - increases the open height.
Turning anti-clockwise - reduces the open height.
- 4. Remove the crank and stow it away.
- 5. Tighten the fastening screws of the clamping plate. Observe the tightening torques, see [Inspecting the fastening of the press head, Page 65](#).
- 6. **NOTE!** Damage on the tool! The tool must be aligned!
- 7. Place the cover on the press frame.

8.5 Fine adjustment of working stroke

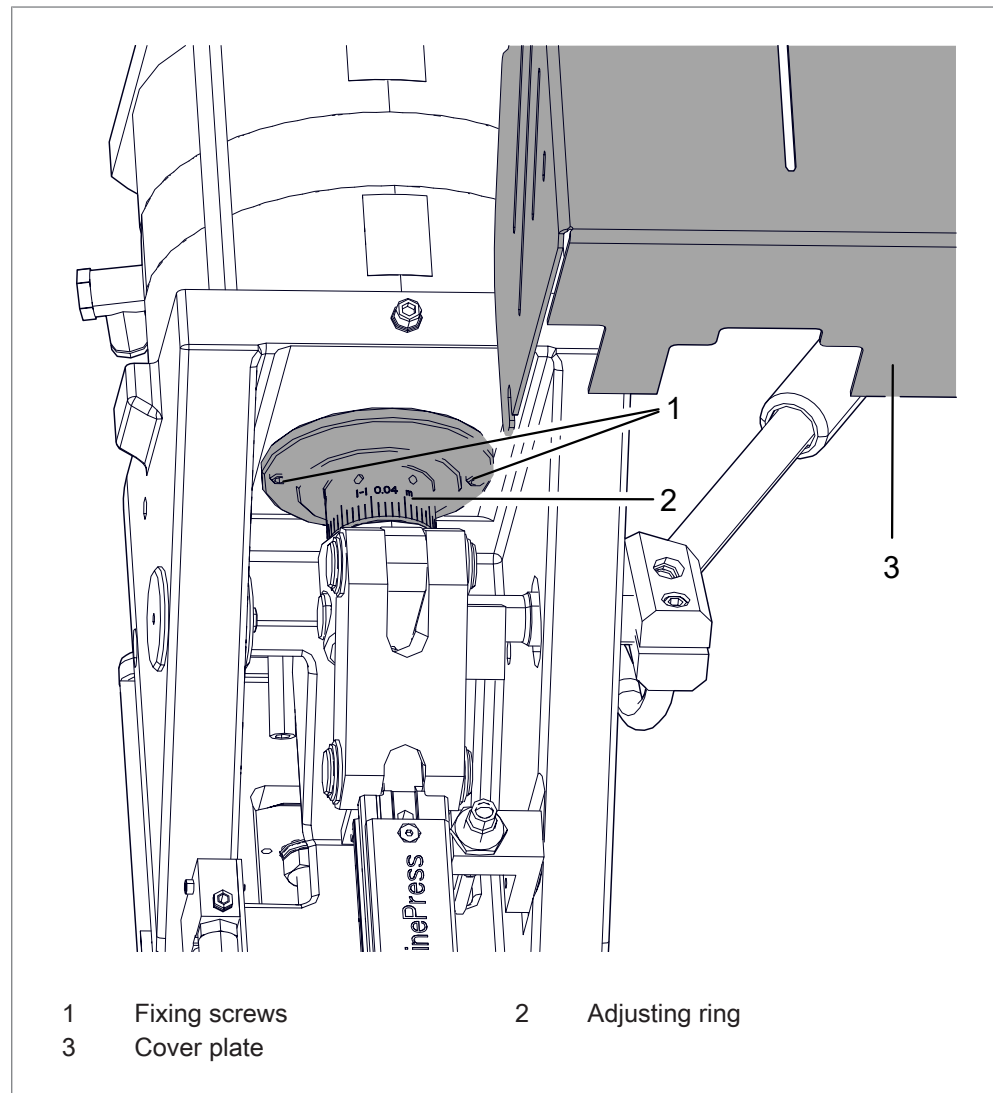

1. Dismantle the cover plate.
2. Loosen the fixing screws.
3. Turn the adjusting ring to adjust the open height.
Turning anticlockwise - increases the open height.
Turning clockwise - reduces the open height.
4. Tighten the fixing screws.
5. Install the cover plate.

8.6 Resetting the stroke counter (optional)

The stroke counter has a reset button.

→ Press the stroke counter button.

9 Troubleshooting

9.1 Safety during troubleshooting

Faults may only be eliminated by trained and authorized service personnel.

The following applies:

- Inform operating personnel before starting repair work.
- Appoint a supervisor.

9.2 Detecting faults

If the press is equipped with a control system, the faults or warnings on the central control unit are displayed and described.

Fault	Cause	Measures
The ram does not extend.	There is a mechanical fault on the guide.	Contact authorized service personnel.
Power stroke does not initiate	Insufficient air pressure	Check the air pressure.
	Pneumatic line on cylinder is defective	Contact authorized service personnel.
	Mechanical defect on pneumatic cylinder	Contact authorized service personnel.
	Fault on control system	Contact authorized service personnel.
The nominal force not reached.	There is a mechanical fault on the guide.	Contact authorized service personnel.
	The press head is not adequately fastened.	Tighten the fastening screws evenly. Observe the tightening torques, see: Inspecting the fastening of the press head, Page 65).

Maintenance table

The specified intervals are only approximate values. Depending on the area of application, the actual values may differ from the guide values. The actual intervals can be found in the system control.

Maintenance cycle	Additional information	
Weekly	10.3.1	TOX®-FinePress inspecting
Monthly	10.3.3	Inspecting and cleaning movable parts and guides
Half-yearly	10.3.2	Inspecting the fastening of the press head

10 Maintenance

10.1 Safety during maintenance

⚠ DANGER**Electrical hazards in case of contact with live parts!**

Electric shock, burns or death in case of contact with live parts!

- Have all work on the electrical equipment performed by an electrician.
 - Disconnect power supply.
 - Wait for residual energy to dissipate safely (at least 3 minutes).
-

⚠ WARNING**Ejecting parts and compressed air from compressed air conducting lines!**

Serious injuries to eyes and body cavities!

- Always connect and disconnect lines without pressure.
 - Pay attention to maximum permitted pressures.
 - Wear individual protective equipment.
-

⚠ WARNING**Dangerous machine movements!**

Serious contusions and injuries!

- Make sure that that no persons are located in the danger area during operation.
-

NOTE**Incorrect cleaning agents or cleaning processes, lack of corrosion protection!**

Damage to machine components!

- Only touch bare areas with gloves.
 - Use cleaning set, such as industrial cleaner (e.g. Loctite 7063, or Würth Montagekraftreiniger 0890 107), vacuum cleaner, dry cloth and brush.
 - Do not clean with compressed air but with suction.
 - After cleaning, protect bare outer surfaces from corrosion. Coat surfaces with a cloth slightly moistened with anticorrosive fluid.
 - Keep inside surfaces, especially element-carrying parts, dry and free of grease.
-

10.2 Requirements for maintenance

10.2.1 Set system to maintenance position

Unless specified otherwise, before all maintenance work:

1. Retract the working piston.
 - ▷ Drive is in home position.
2. Install a restraint device if necessary.
3. Switch off the system and secure it against being switched back on.
4. Turn off the compressed air, secure it against being turned on again and vent the lines, unless expressly stated otherwise.
5. Make sure that unauthorized, accidental or unexpected starting up of the machine and initiation or dangerous movements due to latent energies are prevented.

10.3 TOX®-FinePress maintaining

10.3.1 TOX®-FinePress inspecting

- ✓ System is in maintenance position.
See [Set system to maintenance position, Page 63](#).
- 1. Check the plant, particularly moving parts for obvious defects and damage.
- 2. Check all parts inside and outside for wear, obvious defects and damage.
- 3. Check the supply connections for tightness.

10.3.2 Inspecting the fastening of the press head

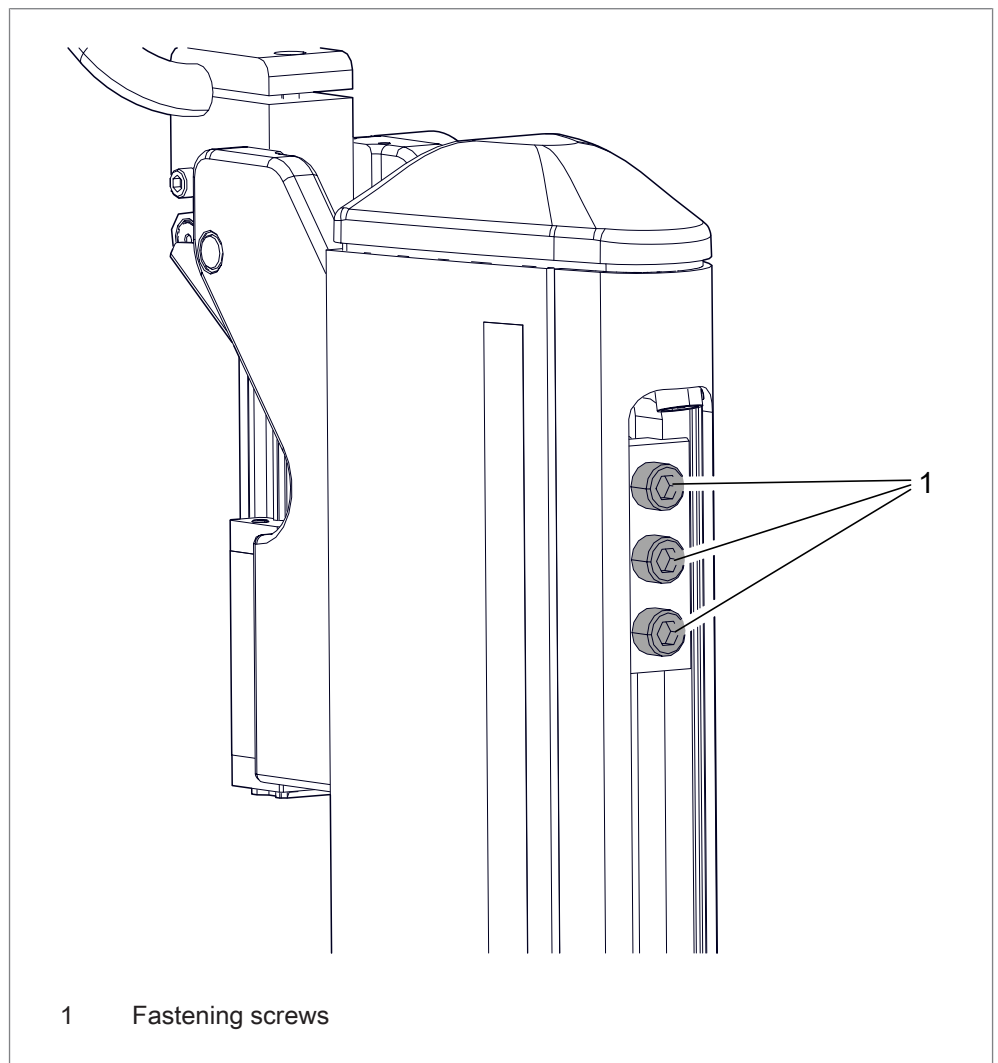

- ✓ System is in maintenance position.
See [Set system to maintenance position, Page 63](#).
- 1. Check the tightening torque of the fastening screws.
- 2. **NOTE!** Damage on the tool! Check the alignment of the tool!

Screw size	Tightening torque
M 12	135 Nm
M 16	340 Nm

Tab. 2 Fastening screws of the press head on the frame

10.3.3 Inspecting and cleaning movable parts and guides

- ✓ System is in maintenance position.
See [Set system to maintenance position, Page 63](#).

NOTE

Incorrect cleaning agents or cleaning processes, lack of corrosion protection!

Damage to machine components!

- Only touch bare areas with gloves.
- Use cleaning set, such as industrial cleaner (e.g. Loctite 7063, or Würth Montagekraftreiniger 0890 107), vacuum cleaner, dry cloth and brush.
- Do not clean with compressed air but with suction.
- After cleaning, protect bare outer surfaces from corrosion. Coat surfaces with a cloth slightly moistened with anticorrosive fluid.
- Keep inside surfaces, especially element-carrying parts, dry and free of grease.

-
- Inspect movable parts and guides, clean and lubricate if necessary.

11 Repairs

11.1 Safety and repairs

The system may only be repaired by trained and authorized service personnel.

12 Disassembly and Disposal

12.1 Safety during disassembly and disposal

The dismantling and disposal may only be carried out by trained and authorized service personnel.

DANGER

Electrical hazards in case of contact with live parts!

Electric shock, burns or death in case of contact with live parts!

- Have all work on the electrical equipment performed by an electrician.
- Disconnect power supply.
- Wait for residual energy to dissipate safely (at least 3 minutes).

WARNING

Ejecting parts and compressed air from compressed air conducting lines!

Serious injuries to eyes and body cavities!

- Always connect and disconnect lines without pressure.
- Pay attention to maximum permitted pressures.
- Wear individual protective equipment.

CAUTION

Sharp edges caused by material splintering!

Injuries from worn parts!

- Wear individual protective equipment.
- Do not move fingers along the cutting edges.
- Be particularly careful and attentive.

12.2 Decommissioning

Decommissioning means that the plant is not in operation for a longer period of time but remains at the installation site for recommissioning later.

1. Switch off plant at the main switch.
2. Clean the system and protect it against corrosion.
3. Protect plant against loss of data and deep discharge.

12.3 Shutdown

Shutdown means that the system is shut down permanently and/or is prepared for removal.

1. Stop system and wait for it to come to a standstill.
2. Remove material if necessary.
3. Switch off the system at the main switch and secure it against being switched on again.
4. First disassemble or dismantle after switching off the power (electricity, pneumatics) and after residual energy has safely dissipated (at least 3 minutes).
5. Remove electrical supply line (first at the terminal, then on the machine).
6. Remove compressed air supply line.
7. Remove network connection.
8. Clean the system and protect it against corrosion.
9. Protect open cable ends against penetration of dirt.
10. Do not remove cable identifications.

12.4 Disassembling

The system consists of recyclable materials.

NOTE

Environmental damage!

Improper recycling endangers the environment!

- Dispose of materials separately and properly.
- Regional disposal regulations must be observed.

1. Strip the system down into its constituent parts.
2. Dispose of greases and oils separately.
3. Sort the constituent parts by material and dispose of according to the local regulations.

12.5 Disposal



When disposing of packaging, consumables and spare parts, including the machine and its accessories, the relevant national environmental protection regulations must be complied with.



13 Appendices

13.1 Declaration of conformity

EU DECLARATION OF CONFORMITY

in accordance with the Machinery Directive (2006/42/EC), Annex II 1. A

Original EU declaration of conformity

TOX® PRESSOTECHNIK GMBH & CO. KG herewith declares that the concept and design of the machine specified hereinafter and the execution traded by us

Designation/function	Pneumatic-Press
Product name/module	TOX®-FinePress
Model/type	PFHL, PFHW
Serial number	see type plate

complies with the relevant requirements of the Machinery Directive (2006/42/EC).

Applied harmonized standards:

DIN EN ISO 12100:2011-03	Safety of machinery - General principles for design - Risk assessment and risk minimization
DIN EN 13736:2009-11	Safety of machine tools - Pneumatic presses
DIN EN ISO 4414:2011-04	Pneumatic fluid power - General rules and safety requirements for systems and their components

Documentation officer: Simon Köberle, Riedstraße 4, 88250 Weingarten

Place, date Weingarten, 29.03.2018

Manufacturer TOX® PRESSOTECHNIK GMBH & CO. KG

Signature



Information on the signatory: ppa Albert Rankel

Filing OD

Index

A		F	
Accessories		Faults	
Installing.....	34	Detect	58
Attachment point	29	Fine adjustment	
		Working stroke	54
B		FinePress	
Basic safety requirements	13	Inspecting	64
BDC sensor		Maintaining	64
Install	44	Force sensor	
		Installing.....	36
C		Function description	23
Commissioning	47		
Requirements	48	G	
Safety.....	47	Gender note	8
Safety device	47	Guidelines	7
Conformity	7	Guides	
Contact	11	Inspecting	66
Contusion			
Hazard	17	H	
		Hazard	
D		Contusion.....	17
Declaration of conformity.....	73	Electrical	16
Decommissioning	70	electromagnetic	18
Disassembly	69, 71	Hazardous substances	18
Safety.....	69	hydraulic	17
Dispatch		Laser	18
Repair	30	Noise.....	19
Disposal.....	69, 71	Pneumatic.....	17
Safety.....	69	Thermal.....	16
Document		Hazard potential	16
additional	8	Hazardous substances	18
Validity	8	Hydraulic	
Drive/Fastening		Hazard	17
Inspecting	65		
E			
Electromagnetic			
Hazard	18		
Exclusion of liability	7		

I		N	
Images		Noise	
Highlighting	10	Hazard	19
Important information	7	Note	
Information		Gender	8
Important.....	7	General	10
Inspection		Legal	7
Drive/Fastening.....	65	Warning signs	9
FinePress.....	64		
Guides	66	O	
Installation	31	Open height of the press head	
Accessories	34	Setting.....	51
BDC sensor	44	operation	49
Force sensor.....	36	Process monitoring	50
Process monitoring	34	Requirements	49
Requirement	33	Safe	21
Safety.....	31	Safety.....	49
Set-up location.....	33	Organizational measures	14
Slide table	40		
Stroke counter	35	P	
TDC sensor.....	42	Press force	
Tool holding fixture	41	Table.....	25
Intended use.....	21	Process monitoring	
		Installing.....	34
L		Process monitoring system	
LABS	22	Operate.....	50
Laser		Product overview	23
Hazard	18		
Legal note.....	7	Q	
		Qualifications	15
M			
Maintenance.....	61	R	
FinePress.....	64	Repair	
Requirement	63	Dispatch.....	30
Safety.....	61	Repairs	67
Maintenance position	63	Requirement	
Measures		Installation.....	33
Organizational.....	14	Maintenance	63
Misuse	22	Reset	
Mounting		Stroke counter	55
Travel sensor	38		

S

Safety	13
Commissioning	47
Disassembly	69
Disposal	69
Installation.....	31
Maintenance	61
Operation	49
Transport	27
Troubleshooting	57
Safety device	
Commissioning	47
safety requirements	
Basic	13
Operating company	14
Safety symbols	20
Selection	
Personnel.....	15
Selection of personnel.....	15
Setting	
Open height of the press head	51
Set-up location	33
Shutdown	70
Slide table	
Installing.....	40
Source of supply.....	11
Storage.....	27, 28
Stroke counter	
Installing.....	35
Resetting.....	55
Substances harmful to the wetting properties of lacquers (LABS).....	22

T

Target group.....	8
TDC sensor	
Install	42
Technical data	25
Texts	
Highlighting	10
Tool holding fixture	
Installing.....	41
Transport	27
Attachment point.....	29
Safety.....	27
Travel sensor	
Installing.....	38
Troubleshooting.....	57
Safety.....	57

U

Use	
Intended.....	21

V

Validity	
Document	8

W

Warning signs.....	9
Working stroke	
Fine adjustment	54

